



Prio[®] Expert

M0600

Reverse Osmosis
Filtration System
with Pump Box



(Storage Tank,
Pump Box Unit with Auto-Flush,
Main Filtration Unit Set)

User's Guide

Before operating this appliance, please read the instructions carefully. You may want to save this guide for your future reference. Failure to follow the instructions or meet the operating requirements may lead to the product's failure, malfunction, property damage or personal injury.



Safety Warning

- Plug the pump unit into an electrical outlet only after you finish the installation.
- Check if the voltage indicated on the pump unit corresponds to the local mains voltage before you connect the appliance.
- Do not use the pump unit if it is damaged in any way. Take it to an authorized service center for repair.
- Do not open the pump unit. There are no serviceable parts inside.
- When unplugging the pump unit from the mains, do not pull on the power cord. Avoid touching the plug with wet hands.
- Do not block air vents of the pump unit or place any items on it. Do not place it near the sources of heat, radiators, etc. Do not place it in a tightly closed space where it may overheat.
- Do not place the storage tank near the sources of heat, radiators, etc.
- Keep the appliance out of reach of pets or other animals.
- In case of leakage malfunction or water presence around the appliance shut off the electrical power to the circuit first, then pull the plug out of the electrical outlet.
- Remove the plug from the electrical outlet and shut off the inlet valve during your vacations or other extended periods of time when the appliance is not in use.
- Unplug the pump unit from the electrical outlet while servicing the main filtration unit, and changing the membrane or filters.
- Do not use the appliance if operating requirements such as water temperature/water pressure/electrical supply, etc. are not met. There may be other local regulations to comply with.
- Do not use the appliance with water that is microbiologically unsafe or of unknown quality without adequate disinfection before or after the system.
- The pump unit was not designed to be used with power cord extenders, power filters, external transformers, outlet splitters, etc.
- Do not use the waste water produced by the appliance for drinking or cooking.
- Never store or operate the appliance in direct sunlight.
- This appliance is not intended for use by persons (including children) with reduced physical, sensory or mental capabilities, or lack of experience and knowledge, unless they have been given supervision or instruction concerning use of the appliance by a person responsible for their safety.
- Children should be supervised to ensure that they do not play with the appliance.
- At the end of its life, the appliance should be disposed off in an appropriate manner.



Disposal

Old appliances still contain many recyclable materials. Therefore, please take used unit to your retailer or recycling center so that it can be recycled.

Description

Congratulations on your purchase of the Prio® Expert R.O. filtration system! With proper installation and maintenance, it will provide you with high quality drinking water for many years.

This R.O. system removes odor and most harmful substances such as heavy metal ions and total dissolved solids from tap water making it tasty, fresh and vital.

This Reverse Osmosis filtration system consists of two units: the sophisticated pump box with auto-flush control valve and booster pump and the R.O. filtration unit with the R.O. membrane. To store the filtered water the pressure tank is used.

Please familiarize yourself with the general concept behind the product and main modes of operation.

Key Features:

- Clean and safe drinking water right in your home. No need to transport and dispose of bottled water any more.
- Factory-preinstalled filters and membrane for faster and easier setup.
- Filters and membrane quick-change housings for easy regular maintenance.
- Compact and beautiful design.
- Automatic flush valve: for peak performance and healthier membrane. 18 seconds of powerful flush at the end of each water filtration cycle prevent the scale and debris build-up on the membrane outer surface.
- The booster pump increases pressure to radically improve the performance and effectiveness of the R.O. unit in all three key areas: increases filtered water flow (production rate), increases rejection rate (improves water purification quality), increases recovery rate (decreases amount of waste water).
- Prolongs the membrane and pre-filter(s) service life due to increased recovery rate.
- Fully automatic operation of the pump box unit: just open the faucet and get clean water instantly; automatic shut off and flush.
- LED indicators: easily understand what the state of your R.O. unit is.
- Split, flexible installation possible where needed: install the pump box up to 50 feet away from the R.O. unit itself. Useful for the situations like lack of space or lack of electrical outlet under the sink, or moving the unit to more appropriate place.
- Idling protection: if you forget to shut off the filtered water faucet for a long time the pump will shut down automatically for you.
- Full separation of electrical components from the membrane and filters of the main R.O. unit makes the regular servicing of your R.O. machine both easy and safe: no need to worry about electrical valves and wires while changing your water filters or membrane.
- Quick fittings for easy tube connections and change of filters.

How It Works:

The MO600 reverse osmosis system is a multi-stage automatic filtration machine. The system consists of the two main units – the pump box and the R.O. unit – which are connected with three tubes. This inter-unit connection distance is up to 50 ft. Water supply is done through the inlet valve, filtered water is first stored in the water tank and then delivered through the faucet, and waste water is drained through the drain saddle. Detailed connection scheme is shown on the following charts.

Usually, both units – the pump box and the R.O. unit with tank – are placed under the sink (such as in your kitchen) and the filtered water faucet is mounted on the sink deck near your normal water tap. After installation, you will get clean water by simply opening the filtered water faucet. The pump will turn on automatically and will produce filtered water to refill the tank. Once in each water production cycle the membrane will be flushed for 18 seconds.



LED Indicators (on the Pump Box Unit):

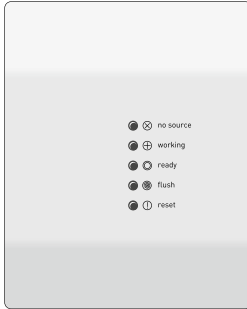

- **No Source:** there is no water in the inlet line or it's pressure is less than 7.25 psi (0.05 MPa). Make sure the inlet tube is connected and not kinked, and the water inlet valve is open.
- **Working:** the pump is working and connected R.O. unit is producing the filtered water for you while either filtered water faucet is open or tank is not full yet. No action is required.
- **Ready:** filtered water faucet is shut and water storage tank is full. The pump is off. No action is required.
- **Flush:** 18 s membrane flush is going. No action is required.
- **Reset:** idling protection was triggered. The pump is off. To restore normal operation power cycle the pump box unit.

Note: for select markets the pump box unit is equipped with the manual flush button. You may press it to start 30 second extended flush.

Pressure Switches:

The pump box unit is equipped with low and high pressure switches. The low pressure switch shuts off the pump when there is no inlet water or its pressure is too low. The high pressure switch shuts off the pump when the filtered water faucet is turned off and water storage tank is full.

Pump:

The pump box unit is equipped with a low voltage booster pump powered by the included transformer for safe operation.

Inlet Valve:

An adapter ball valve is included to be installed into the cold water supply line to feed water to the pump box inlet.

Faucet:

Designer faucet for filtered water is included and usually mounted on the sink deck or countertop for dispensing the clean, filtered water from the filtered water storage tank.

Water Storage Tank:

Air pressurized 4.0 gallon storage tank (with holding capacity up to 2.5G) is used for filtered water storage.

Drain saddle:

Fits a standard 1.5" diameter drain pipe to drain the waste water from the drain outlet of the pump box.

Pre-Filters:

The main R.O. unit has two pre-filters: sediment pre-filter on the first stage and activated carbon pre-filter on the second stage. They provide initial filtration of the water and protect the following thin film composite R.O. membrane from dirt and aggressive chemicals such as chlorine often found in tap water.

R.O. Membrane:

The third and main stage of the filtration is R.O. membrane. It is “semi-permeable”, which means that it allows water to pass through but prevents dissolved particles from passing through. It splits the feed water into two streams: clean water goes to the post-filter and then onto the tank and faucet. Waste water with rejected particles goes down the drain.

Post-Filter:

Last stage of filtration is an activated carbon post-filter and/or remineralization for fine conditioning and keeping the extra freshness of your water.

Specification

Operating Requirements:

- Minimum supply water pressure: 7.25 psi (0.05 MPa)
- Maximum supply water pressure: 80 psi (0.55 MPa)
- Minimum water temperature: 41 °F (5 °C)
- Optimal water temperature: 59–77 °F (15–25 °C)
- Maximum water temperature: 95 °F (35 °C) / up to 105 °F (40.5 °C) short-term
- Ambient air temperature: 41–105 °F (5–40.5 °C)
- Water source: tap water supply, chlorinated or non-chlorinated, bacteriologically safe
- Supply water pH range: 4.0-11.0
- Supply water turbidity: < 1 NTU
- Supply water components: Hardness (CaCO₃) <180 mg/L (<10.5 gpg), Iron <0.1 mg/L, Manganese <0.05 mg/L, Hydrogen Sulfide 0.00 mg/L
- Maximum supply water TDS: 1000 ppm
- Indoor use only.
- Electrical input: AC 100-240V 50/60 Hz
- Maximum length of the line between the pump unit and the membrane (“split installation”): 50 ft (15 m) (purchase of extra tubing may be required)
- Tubing: ¼”

Performance:

Performance of the appliance such as filtered water delivery rate, rejection rate, etc. is highly dependent on local conditions (inlet water pressure, temperature, TDS and degree of contamination, tank air pressure, etc.) and R.O. system use pattern. Actual performance may vary.

- Filtered water production rating: 75 gpd (270 lpd) maximum
- Filtered water delivery rate (from the tank), typical: 0.27–0.74 gpm (1–2.8 l/min)
- Membrane rejection rate¹, typical: ≥90%
- Recovery rate (system efficiency²), typical: ≥15%
- Drain water flow restrictor: 300 cc (ml/min) nominal, up to 360 cc in working mode, open flow in flush mode.
- Auto-flush duration: 18±10% s
- Tank Storage Capacity (Total Volume): up to 2.5G (4.0G)

¹ For all dissolved solids combined as measured by TDS or conductivity meter.

² Efficiency rating means the percentage of the influent water to the system that is available to the user as reverse osmosis treated water under operating conditions that approximate typical daily usage.

- Tank full refill time, typical: 35-45 min
- Idling protection: 120 minutes (the pump box unit shuts down the pump and goes into 'reset required' mode if working mode continuous duration reaches 2 hours without interruption)

Weight and Size:

Pump box unit:

Size (WDH), body only, excluding protrusions: 8.74 x 4.80 x 12.44" (222 x 122 x 316 mm)

Weight, without water and tubing: 8.6 lbs (3.9 kg)

R.O. filtration unit:

Size (WDH), body only, excluding protrusions: 13.46 x 3.35 x 14.80" (342 x 85 x 376 mm)

Weight, without water and tubing: 8.8 lbs (4.0 kg)

Storage tank:

Size (WDH), body only, excluding protrusions: 10.55 x 10.55 x 14.90" (268 x 268 x 378 mm)

Weight, without water and tubing: 6.0 lbs (2.7 kg)

Warranty:

1 year limited warranty

Package Contents:

- | | |
|---|------------------------------------|
| (1) The auto-flush booster pump box unit | (1) Drain saddle |
| (1) The R.O. filtration unit | (1) Wrench |
| (1) Storage tank | (1) ¼" tank valve |
| (1) Universal worldwide adapter ball valve
(G1/2" - G3/8" - UNEF 9/16"-24 - JG 1/4") | (26 ft / 8 m) Water tubing ¼" |
| (1) Teflon tape roll | (1) ¼" x ¼" union check valve |
| (1) Faucet | (2) ¼" x ¼" x ¼" union tee fitting |
| | User's guide |

Installation

Notes:

1. Shut off the cold water supply under the sink or the location where the system will be installed. If the existing valve is inoperable, the water supply to the house must be shut off. Then, relieve the water pressure by opening the cold water tap. Do not connect the system to hot water source.
2. Depending on your plumbing system and sink/countertop type you may need to use tools like variable speed drill, drill bits, screw driver, wrench, etc. You may want to ask a professional service provider such as certified plumber to install the inlet valve adapter, faucet, and drain saddle to assure a trouble-free setup.
3. During installation you will need to cut the supplied ¼" tubing into segments as needed. Use your utility knife for that or similar tool. See the following charts to determine the connection scheme and length of hoses necessary. You may need to purchase extra tubing for far-reaching split or other corner case installations.
4. Do not connect the pump box unit to the electrical supply until the setup is completed.
5. With initial operation, check for leaks. If a leak is observed, verify that the tubing is pushed into the quick fitting far enough to seal the tubing against the O-ring and that the tubing was cut at 90°

General connection scheme:

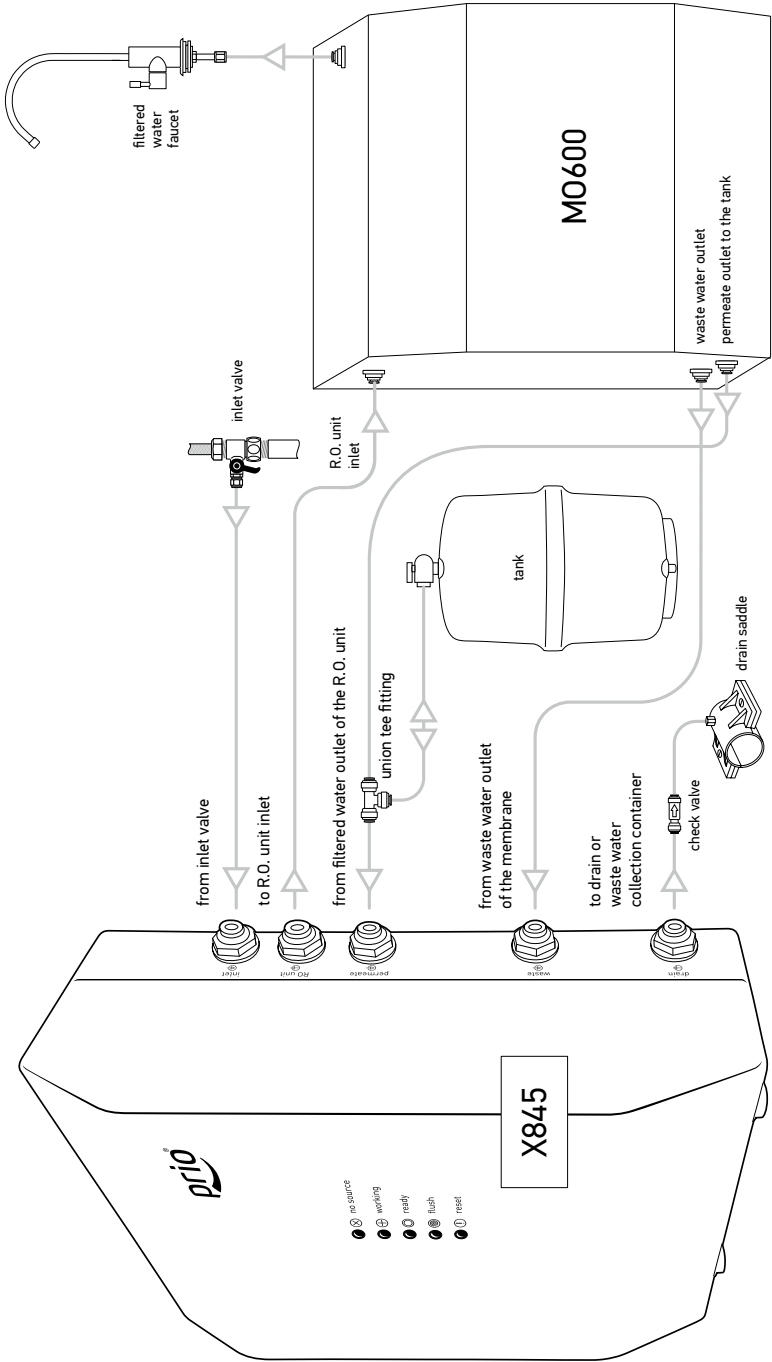

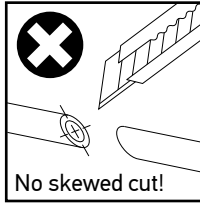
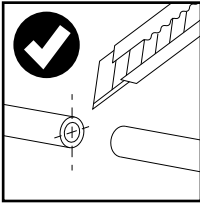

IMPORTANT: Cut Tubing At 90° to Ensure a Watertight Seal:

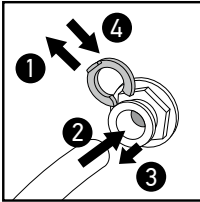

To Connect the Tubing to a Fitting:

1. Remove the lock if present (not present in self-locking fittings).
2. Push. Insert the tube firmly until full stop.
3. Pull the collet back slightly.
4. Replace the lock (if present).

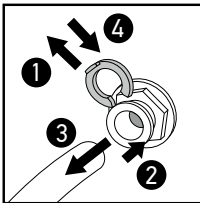

To Disconnect the Tubing:

1. Remove the lock if present (not present in self-locking fittings).
2. Push the collet **and hold**.
3. Pull the tubing out.
4. Replace the lock (if present).

Units Placement Guide:

Pump box unit

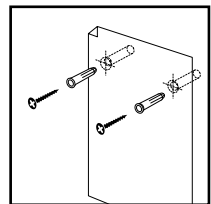
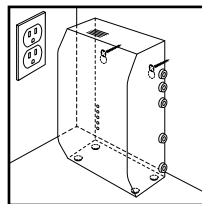
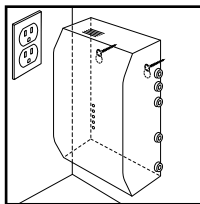
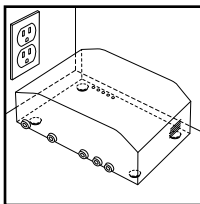

R.O. filtration unit

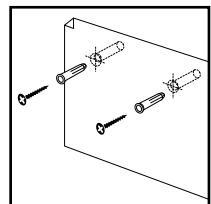
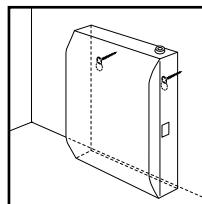
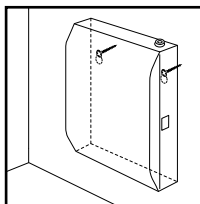
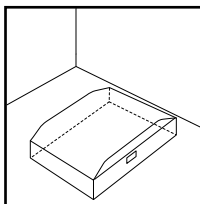

Remember this unit must be serviced at regular intervals. Therefore it should be reasonably accessible (for changing filters or membrane, etc.).

The maximum length of hose connections between the pump box unit and R.O. filtration unit is 50 ft. You may place both units under your kitchen sink, or you may place the R.O. filtration unit with the water storage tank under the sink in your kitchen near the faucet, and the pump box unit in your bathroom near the electrical outlet, cold water supply and drain pipes.

Installation Steps:

1. Install adapter ball valve (included) to the cold water supply.

Use some Teflon or plumbers sealing tape to prevent leaks. Use three included threaded adapters to make different connection configurations (see chart for details).

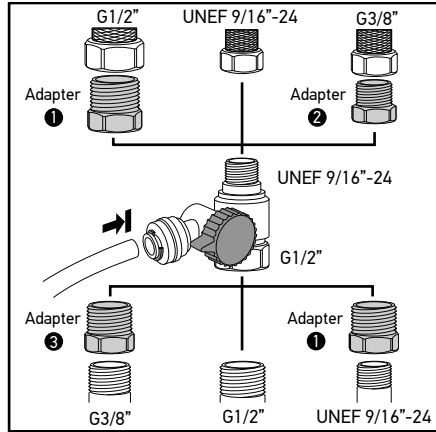

2. Create 1/2\"/>

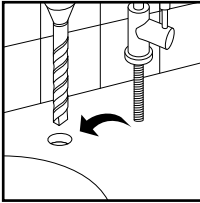

Tip: If you have a soap dispenser or a water sprayer in an existing hole you may remove it and use its hole for the filtered water faucet.

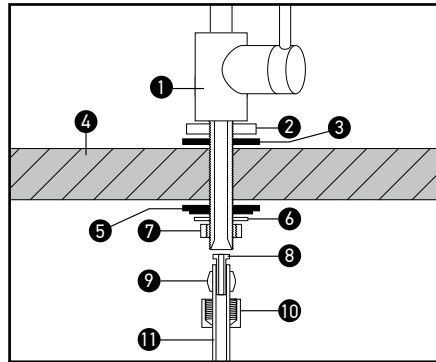

- | | |
|----------------------------|---------------------|
| 1. Faucet | 6. Lock washer |
| 2. Chrome washer | 7. Lock nut |
| 3. Black rubber washer | 8. Insert |
| 4. Countertop or sink deck | 9. Sleeve |
| 5. Black washer | 10. Compression nut |
| | 11. Tubing |

3. Install drain saddle.

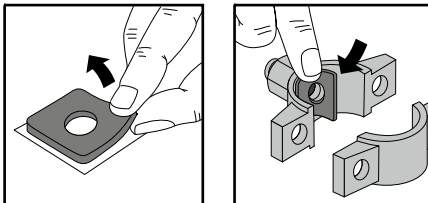

The square foam gasket with a circle cut out must be applied to the inside of the drain saddle. Remove sticky tape backing and stick to the drain saddle as shown.

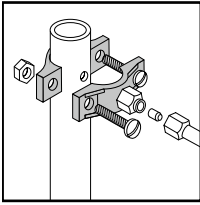

Drill a ¼” hole in the drain pipe **above the trap** and on the vertical or horizontal tail piece. Locate the drain connection away from the garbage disposal to prevent potential contamination and system fouling.

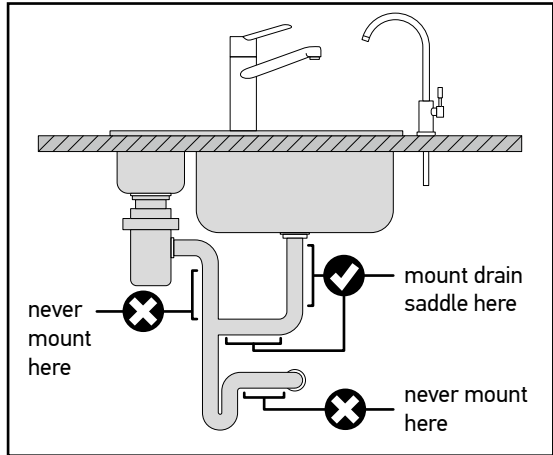

4. Install water storage tank and mount tank valve.

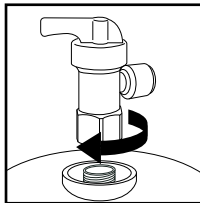
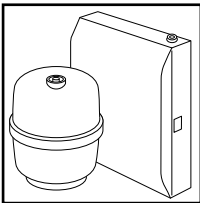

Tank is a clean water storage container. Never place the tank in direct sunlight or near the sources of heat. It's recommended to have the tank been installed near the R.O. filtration unit and the faucet.

Mount tank valve on the inlet-outlet port of the tank. Use some Teflon or plumbers sealing tape to prevent leak.

5. Remove gags and connect tubes as follows. See the connection chart for details.

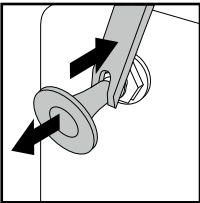

- Insert water supply tubing from inlet valve adapter into the “inlet” fitting of the pump box unit.
- Insert the supply tubing from the “RO unit” fitting of the pump box unit into the supply inlet of the R.O. filtration unit.
- Connect with the tubing the “tank” outlet fitting of the R.O. filtration unit with the “permeate” fitting of the pump box unit through the T-fitting on the way. Then connect with the tubing the branch of the T-fitting with the tank valve fitting.
- Insert the waste tubing from the waste water outlet of the R.O. filtration unit into the “waste” fitting of the pump box unit.
- Insert the waste tubing from the “drain” fitting of the pump box unit into the drain saddle (through the optional union check valve on the way) or to a waste water collection container. Install the check valve with the arrow in the direction of flow.
- Insert filtered water tubing from the “faucet” outlet fitting of the R.O. filtration unit into the faucet using insert, sleeve and compression nut. See faucet installation chart for details.

Initial Washing:

After installation it is recommended to perform the initial washing of the system. For this:

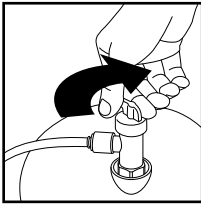

- shut off the tank valve;

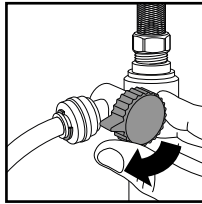

- open cold water supply valve;
- open the inlet valve;

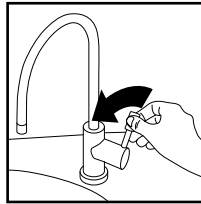

- open the filtered water faucet;

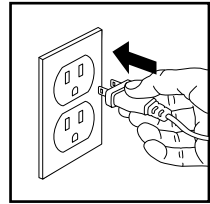

- plug the pump box unit's power cord into the electrical outlet;

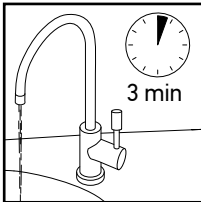

- wait for water to arrive at the faucet (it may take a while, especially first time, water foam and air may be going out of the system);

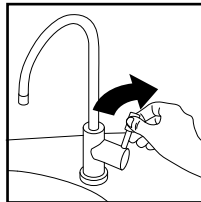

- after water flow appears from the faucet (the flow is weak and inconsistent) wait for 2-3 minutes more and shut off the faucet;
- wait for auto flush to complete (18 s);

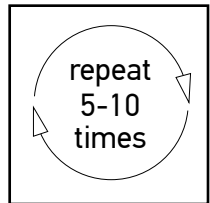
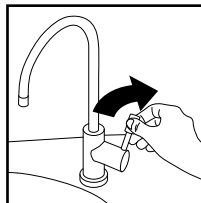
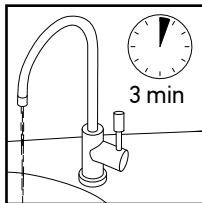
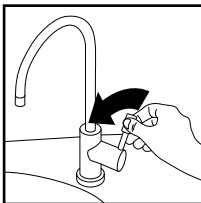

- repeat the cycle "open the filtered water faucet – wait for 3 minutes – shut off the filtered water faucet – wait for auto flush to complete" 5-10 times;
- after you finished with previous step shut off the faucet, and open the tank valve;
- wait for tank full refill then drain the tank by opening the faucet;
- repeat tank refill and drain once again by shutting off and opening the faucet, then shut off the faucet and wait for tank refill with clean water;
- your system is ready for use.

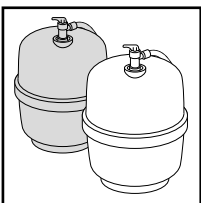

Regular Use

To get clean water just open the filtered water faucet. The filtered water stored in the tank will be delivered. The pump will turn on automatically and will refill the tank gradually even after you shut off the faucet. The system will shut off automatically when the tank will become full again. Once in each water production cycle the membrane will be flushed.

Please note that R.O. membrane needs up to 50 hours of active operation before reaching peak performance in terms of water flow, recovery and rejection rates. The delivery rate and available amount of filtered water depend on how full the tank is. You may need to shut off the faucet and wait for the tank refill to get more water.

For your safety and peace of mind please unplug the pump box unit from the electrical outlet and close the inlet valve before servicing your R.O. system such as changing filters or membrane, or during vacations.

Tips:

- You may install the optional union tee fitting to the tubing line prior to the filtered water faucet to get another line of clean water going to the other point-of-use (such as a sink in a bathroom or ice maker in your fridge).
- Operating the system using softened feed water greatly reduces the chances of membrane failure and prolongs filters and membrane service life.

Changing Filters and Membrane

This R.O. system contains the replaceable components critical to the efficiency of the system. Replacement of a component should be with one of identical specifications, as defined by the manufacturer, to assure the same efficiency and contaminant reduction performance.

To reduce the risk of water leakage or flooding, and to ensure optimal R.O. system performance:

- Change the disposable pre-filters every 6 months or sooner if you observe a noticeable reduction in water production rate.
- Change the disposable post-filter every 12 months or sooner if you observe a noticeable reduction in water flow or production rate.
- Change the disposable R.O. membrane every 24 months or sooner if you observe a noticeable reduction in water production rate.

Failure to replace the disposable filters & membrane at recommended intervals may lead to reduced system performance and cracks in the filter housings, causing water leakage or flooding.

Please note the capacity of the filters and membrane is limited. Their service life depends on the degree of contamination of the water supply and system usage. All terms apply to normal household use. Actual performance may vary. You may need to change filters or the membrane sooner than indicated if you notice chlorine or other tastes or smells, etc. Manufacturer recommends a TDS test every six months.

Replacement Filters:

- K871 (sediment pre-filter)
- K870 (activated carbon pre-filter)
- K866 (R.O. membrane)
- K880 (activated carbon post-filter and conditioner)

Optional post-filters which can also be used instead of K880:

- K875 (granular activated carbon post-filter)
- K873 (granular activated carbon with schungite natural mineral post-filter)
- K870 carbon block pre-filter may also be used as a post-filter.

To prevent leakage or cracks and ensure the safety of operation and top performance do not disassemble the filters or try to regenerate them.

To change filter(s) or membrane:

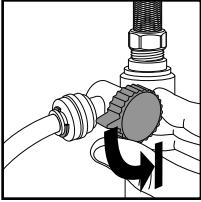

- shut-off the inlet valve

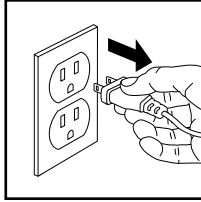

- unplug the pump box unit from the electrical outlet

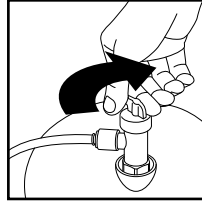

- shut off the tank valve

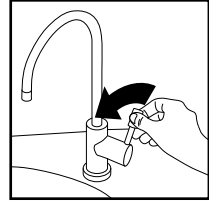

- relieve the water pressure by opening the filtered water faucet

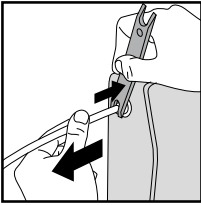

- remove the R.O. filtration unit from its place for easier access (disconnect external tubes if necessary) and open the unit's cover

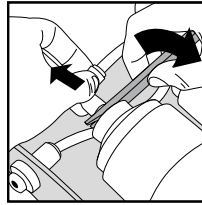
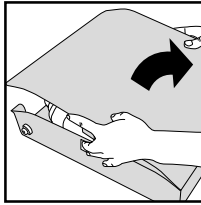

- locate the filter (membrane) to be changed, disconnect its inlet and outlet fittings and remove it

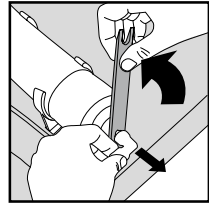

Note: Remove and change back one filter at a time, one after another. Do not remove all filters at once to avoid mixing up the tubes.

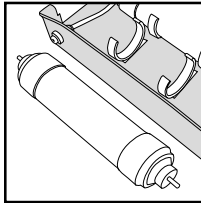
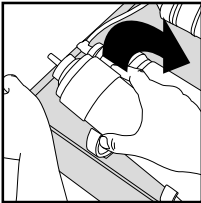

- take new filter (membrane) and install it in the place of the removed one observing the water flow direction arrow on its label and restoring the connections (see the internal connections chart for details)

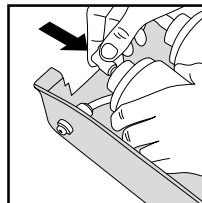
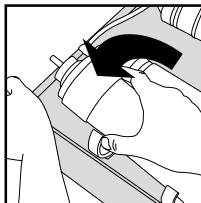
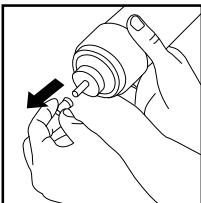

or

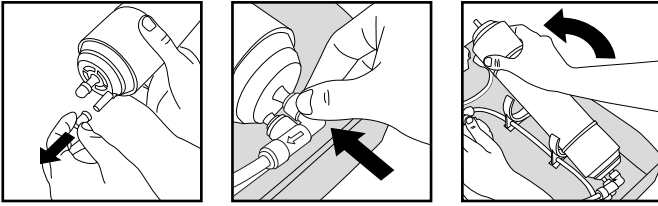

Note: For a pre- or post-filter you only need to connect its inlet and outlet. For the membrane you have to connect the third outlet – to the waste water line. This outlet is located off the center of the membrane housing. Elbow check valve fitting (with the arrow) has to be connected to the central (permeate) outlet of the membrane housing.

- close the cover, reconnect the external tubes and place the unit back in its place

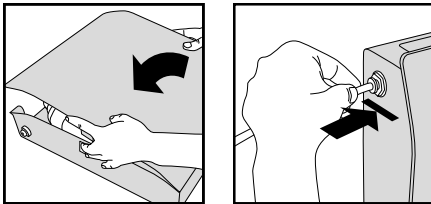

After you finished changing filters or the membrane follow the “initial washing” procedure as described above. With initial operation, check for leaks. If a leak is observed, verify that the tube or branch pipe of the filter/membrane housing is pushed into the quick fitting far enough to seal the tube against the O-ring and that the tubing was cut at 90°.

R.O Filtration Unit Internal Connections Chart

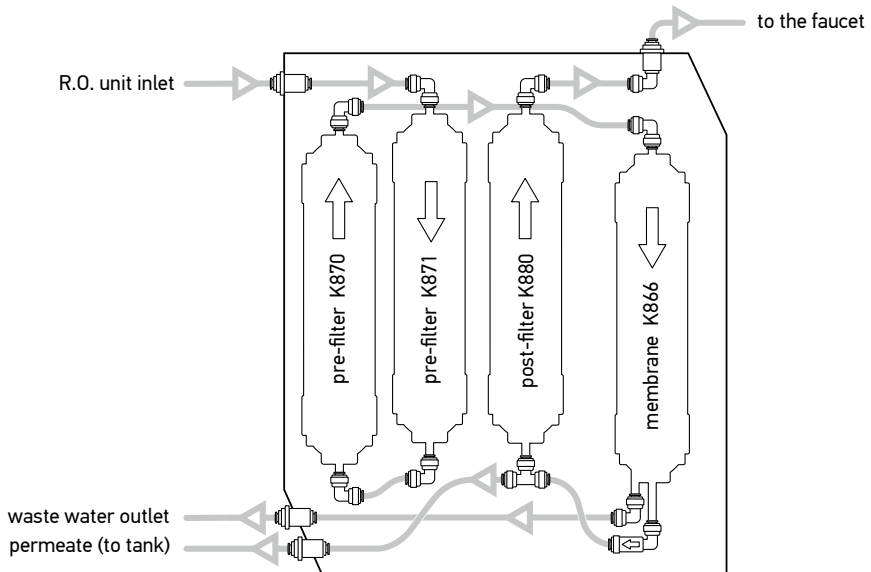

Water Storage Tank Service

Water storage tank may require air repressurizing if you notice low water delivery rate even with full tank.

The storage tank has the bladder inside which separates air from water. On the lower side of the tank there is the air valve connected to the compressed air chamber. The top water inlet-outlet port (where the tank valve is mounted) is connected to the pure water chamber. When you open the faucet, the compressed air would compress the bladder to force the water out of the tank.

In an empty tank, air pressure in the air chamber should be 5-8 psi (0.35-0.55 bar). If pressure drops below this threshold you may notice low delivery rate of pure water from the tank.

To recharge the tank:

- Shut off the water supply valve and unplug the pump box unit from the electrical outlet.
- Drain the tank by opening the faucet to allow water to run until it stops.
- Check to see if there is still water in the storage tank. If the tank feels heavy,

that means you need to recharge the air chamber and continue the following steps. If the tank feels light, that means it is not time yet to recharge the tank at this moment.

- Locate the air valve. Use bicycle tire air pump to pump air into the tank through this valve. Keep the faucet open while pumping air so that all water inside the tank can be purged.
- After all water has been drained from the tank, use an air pressure gauge to check the tank pressure. The tank should have 5-8 psi (0.35-0.55 bar) of pressure when it's empty. Add or purge air if necessary.
- Open the water supply valve, plug the pump box unit to the electrical outlet and close the faucet to allow refilling of the tank.

Please note that storage tank service life is limited. Take into consideration that it stores water of room temperature and is not sterile, thus it may become the source of a secondary contamination over time. Unpleasant smell or taste may appear in the water. If changing the post-filter doesn't solve the problem your tank may require retirement and your system needs a new tank.